

JIS B 2401-G 系列 O-RING 規格表

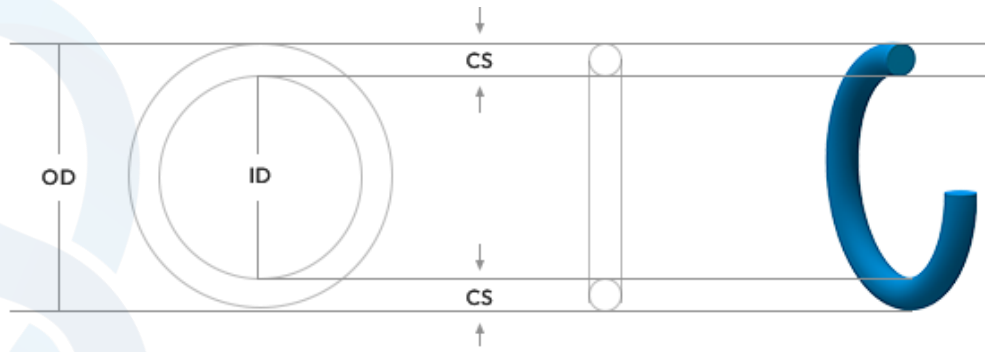

單位 unit:mm

規格	ID(內徑)	OD(外徑)	CS(線徑)
G25	24.4	30.6	3.1
G30	29.4	35.6	3.1
G35	34.4	40.6	3.1
G40	39.4	45.6	3.1
G45	44.4	50.6	3.1
G50	49.4	55.6	3.1
G55	54.4	60.6	3.1
G58	57.4	63.6	3.1
G60	59.4	65.6	3.1
G65	64.4	70.6	3.1
G70	69.4	75.6	3.1
G75	74.4	80.6	3.1
G80	79.4	85.6	3.1
G85	84.4	90.6	3.1
G90	89.4	95.6	3.1
G95	94.4	100.6	3.1
G100	99.4	105.6	3.1
G105	104.4	110.6	3.1
G110	109.4	115.6	3.1
G115	114.4	120.6	3.1
G120	119.4	125.6	3.1
G125	124.4	130.6	3.1
G130	129.4	135.6	3.1
G135	134.4	140.6	3.1
G140	139.4	145.6	3.1
G145	144.4	150.6	3.1
G150	149.3	160.7	5.7
G155	154.3	165.7	5.7
G160	159.3	170.7	5.7
G165	164.3	175.7	5.7

規格	ID(內徑)	OD(外徑)	CS(線徑)
G170	169.3	180.7	5.7
G175	174.3	185.7	5.7
G180	179.3	190.7	5.7
G185	184.3	195.7	5.7
G190	189.3	200.7	5.7
G195	194.3	205.7	5.7
G200	199.3	210.7	5.7
G205	204.3	215.7	5.7
G210	209.3	220.7	5.7
G215	214.3	225.7	5.7
G220	219.3	230.7	5.7
G225	224.3	235.7	5.7
G230	229.3	240.7	5.7
G235	234.3	245.7	5.7
G240	239.3	250.7	5.7
G245	244.3	255.7	5.7
G250	249.3	260.7	5.7
G255	254.3	265.7	5.7
G260	259.3	270.7	5.7
G265	264.3	275.7	5.7
G270	269.3	280.7	5.7
G275	274.3	285.7	5.7
G280	279.3	290.7	5.7
G285	284.3	295.7	5.7
G290	289.3	300.7	5.7
G295	294.3	305.7	5.7
G300	299.3	310.7	5.7
G305	304.3	315.7	5.7
G310	309.3	320.7	5.7
G315	314.3	325.7	5.7

JIS B 2401-G 系列 O-RING 規格表

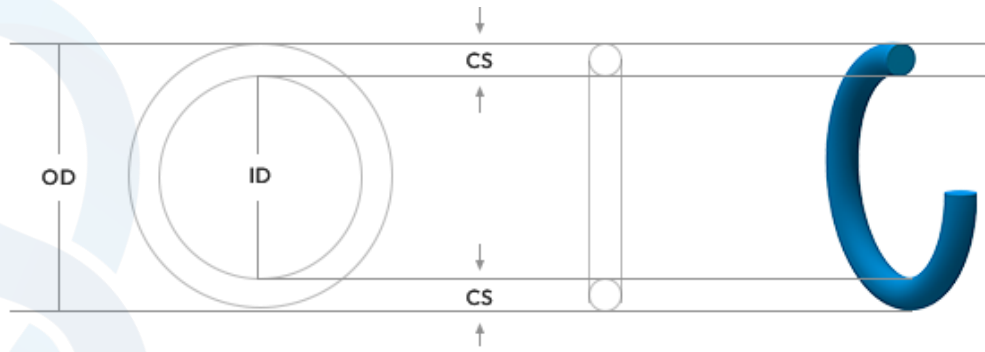

單位 unit:mm

規格	ID(內徑)	OD(外徑)	CS(線徑)
G320	319.3	330.7	5.7
G325	324.3	335.7	5.7
G330	329.3	340.7	5.7
G335	334.3	345.7	5.7
G340	339.3	350.7	5.7
G345	344.3	355.7	5.7
G350	349.3	360.7	5.7
G355	354.3	365.7	5.7
G360	359.3	370.7	5.7
G365	364.3	375.7	5.7
G370	369.3	380.7	5.7
G375	374.3	385.7	5.7
G380	379.3	390.7	5.7
G385	384.3	395.7	5.7
G390	389.3	400.7	5.7
G395	394.3	405.7	5.7
G400	399.3	410.7	5.7
G405	404.3	415.7	5.7
G410	409.3	420.7	5.7
G415	414.3	425.7	5.7
G420	419.3	430.7	5.7
G425	424.3	435.7	5.7
G430	429.3	440.7	5.7
G435	434.3	445.7	5.7
G440	439.3	450.7	5.7
G445	444.3	455.7	5.7
G450	449.3	460.7	5.7
G455	454.3	465.7	5.7
G460	459.3	470.7	5.7
G465	464.3	475.7	5.7

規格	ID(內徑)	OD(外徑)	CS(線徑)
G470	469.3	480.7	5.7
G475	474.3	485.7	5.7
G480	479.3	490.7	5.7
G485	484.3	495.7	5.7
G490	489.3	500.7	5.7
G495	494.3	505.7	5.7
G500	499.3	510.7	5.7
G505	504.3	515.7	5.7
G510	509.3	520.7	5.7
G515	514.3	525.7	5.7
G520	519.3	530.7	5.7
G525	524.3	535.7	5.7
G530	529.3	540.7	5.7
G535	534.3	545.7	5.7
G540	539.3	550.7	5.7
G545	544.3	555.7	5.7
G550	549.3	560.7	5.7
G555	554.3	565.7	5.7
G560	559.3	570.7	5.7
G565	564.3	575.7	5.7
G570	569.3	580.7	5.7
G575	574.3	585.7	5.7
G580	579.3	590.7	5.7
G585	584.3	595.7	5.7
G590	589.3	600.7	5.7
G595	594.3	605.7	5.7
G600	599.3	610.7	5.7
G610	609.3	620.7	5.7
G620	619.3	630.7	5.7
G630	629.3	640.7	5.7

JIS B 2401-G 系列 O-RING 規格表

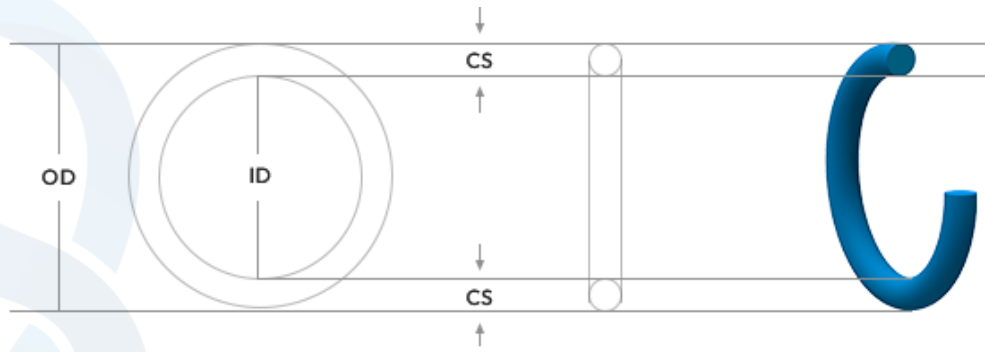

單位 unit:mm

規格	ID(內徑)	OD(外徑)	CS(線徑)
G640	639.3	650.7	5.7
G650	649.3	660.7	5.7
G660	659.3	670.7	5.7
G670	669.3	680.7	5.7
G680	679.3	690.7	5.7
G690	689.3	700.7	5.7
G700	699.3	710.7	5.7
G710	709.3	720.7	5.7
G720	719.3	730.7	5.7
G730	729.3	740.7	5.7
G740	739.3	750.7	5.7
G750	749.3	760.7	5.7
G760	759.3	770.7	5.7
G770	769.3	780.7	5.7
G780	779.3	790.7	5.7
G790	789.3	800.7	5.7
G800	799.3	810.7	5.7
G810	809.3	820.7	5.7
G820	819.3	830.7	5.7
G830	829.3	840.7	5.7
G840	839.3	850.7	5.7
G850	849.3	860.7	5.7
G860	859.3	870.7	5.7
G870	869.3	880.7	5.7
G880	879.3	890.7	5.7
G890	889.3	900.7	5.7
G900	899.3	910.7	5.7
G910	909.3	920.7	5.7
G920	919.3	930.7	5.7
G930	929.3	940.7	5.7

規格	ID(內徑)	OD(外徑)	CS(線徑)
G940	939.3	950.7	5.7
G950	949.3	960.7	5.7
G960	959.3	970.7	5.7
G970	969.3	980.7	5.7
G980	979.3	990.7	5.7
G990	989.3	1000.7	5.7
G1000	999.3	1010.7	5.7